

Wall Bracket

Duvar Konsolu - Настенная консоль, гнутая

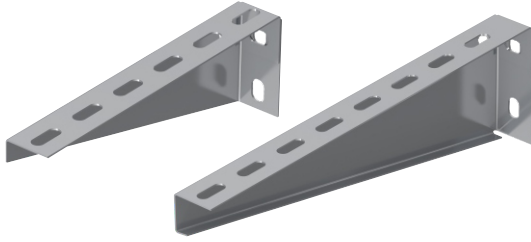

Pre-Galvanized

DK	PG			
CODE	Width of Tray	Length L mm	KG 1 pc	pcs
DK 05 PG	50	60	0,080	100
DK 10 PG	100	110	0,130	50
DK 15 PG	150	160	0,165	50
DK 20 PG	200	210	0,200	50
DK 30 PG	300	310	0,430	50
DK 40 PG	400	410	0,560	50
DK 50 PG	500	510	0,710	25
DK 60 PG	600	610	0,780	25

Hot Dip Galvanized

DK	HDG			
CODE	Width of Tray	Length L mm	KG 1 pc	pcs
DK 05 HDG	50	60	0,084	100
DK 10 HDG	100	110	0,137	50
DK 15 HDG	150	160	0,173	50
DK 20 HDG	200	210	0,210	50
DK 30 HDG	300	310	0,452	50
DK 40 HDG	400	410	0,588	50
DK 50 HDG	500	510	0,746	25
DK 60 HDG	600	610	0,819	25

Wall Bracket (Welded)

Duvar Konsolu (Kaynaklı) - Настенная консоль, сварная

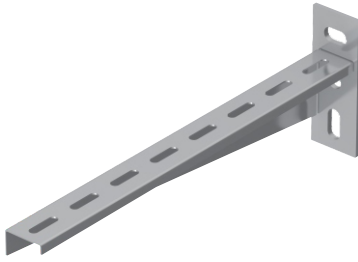

Electro-Galvanized

DKK	EG			
CODE	Width of Tray	Length L mm	KG 1 pc	pcs
DKK 05 EG	50	60	0,210	100
DKK 10 EG	100	110	0,250	50
DKK 15 EG	150	160	0,320	50
DKK 20 EG	200	210	0,380	50
DKK 25 EG	250	260	0,550	50
DKK 30 EG	300	310	0,630	25
DKK 40 EG	400	410	0,750	25
DKK 50 EG	500	510	1,050	20
DKK 60 EG	600	610	1,210	20

Hot Dip Galvanized

DKK	HDG			
CODE	Width of Tray	Length L mm	KG 1 pc	pcs
DKK 05 HDG	50	60	0,211	100
DKK 10 HDG	100	110	0,263	50
DKK 15 HDG	150	160	0,336	50
DKK 20 HDG	200	210	0,399	50
DKK 25 HDG	250	260	0,578	50
DKK 30 HDG	300	310	0,662	25
DKK 40 HDG	400	410	0,788	25
DKK 50 HDG	500	510	1,103	20
DKK 60 HDG	600	610	1,271	20

Brackets for Wall & Floor Mounting

Yere ve Duvara Tespit Elemanı - Настенно-напольная консоль

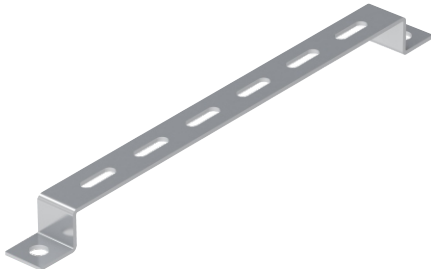

Electro-Galvanized

YDT	PG			
CODE	Width of Tray	Length L mm	KG 1 pc	pcs
YDT 310 PG	100	100	0,140	100
YDT 315 PG	150	150	0,180	50
YDT 320 PG	200	200	0,210	50
YDT 325 PG	250	250	0,250	50
YDT 330 PG	300	300	0,280	100
YDT 340 PG	400	400	0,350	100
YDT 345 PG	450	450	0,390	50
YDT 350 PG	500	500	0,420	50
YDT 360 PG	600	610	0,490	50

Hot Dip Galvanized

YDT	HDG			
CODE	Width of Tray	Length L mm	KG 1 pc	pcs
YDT 310 HDG	100	100	0,147	100
YDT 315 HDG	150	150	0,189	50
YDT 320 HDG	200	200	0,221	50
YDT 325 HDG	250	250	0,263	50
YDT 330 HDG	300	300	0,294	100
YDT 340 HDG	400	400	0,368	100
YDT 345 HDG	450	450	0,410	50
YDT 350 HDG	500	500	0,441	50
YDT 360 HDG	600	610	0,515	50

DK

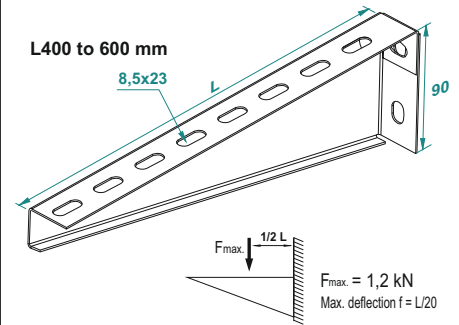
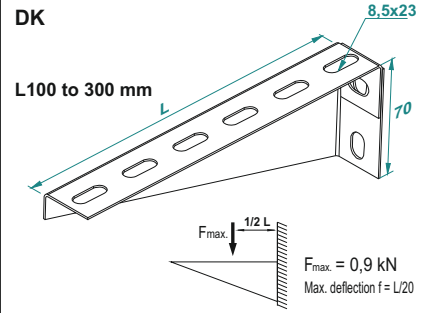

DKK

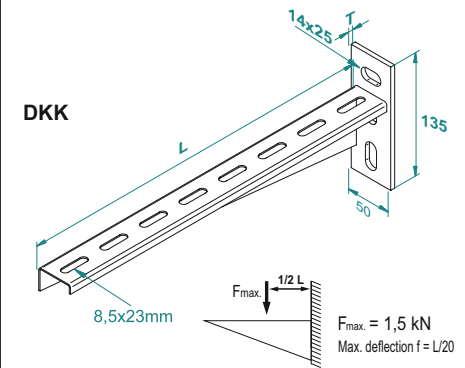

YDT

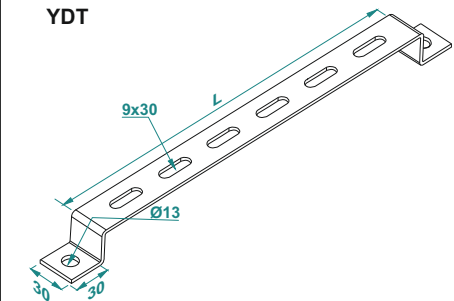

MATERIAL

PG- Sendzimir Method to TS-EN 10346:2011
EG- Electro-galvanized EN ISO 2081
HDG- Steel, hot dip galv. to TS-EN ISO 1461:2011 (HDG)

Available finishes:

SS - Stainless steel AISI 304L and aisi 316L (SS)
EP- powder coating in a full range of colours (RAL)

Brackets for Wall & Floor Mounting

Yere ve duvara Tespit Elemanı - Настенно-напольная консоль

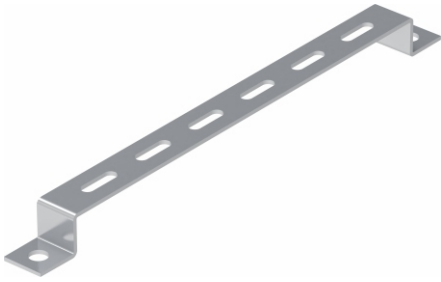

Pre-Galvanised

YDT ... PG		H40				
CODE	Width of Tray	Height H mm	Length L mm	Kg 1 pc	pcs	
YDT 410 PG	100	40	100	0.113	50	
YDT 415 PG	150	40	150	0.137	50	
YDT 420 PG	200	40	200	0.160	50	
YDT 425 PG	250	40	250	0.276	50	
YDT 430 PG	300	40	300	0.311	50	
YDT 440 PG	400	40	400	0.382	50	
YDT 445 PG	450	40	450	0.417	25	
YDT 450 PG	500	40	500	0.452	25	
YDT 460 PG	600	40	600	0.523	25	

Hot Dip Galvanised

YDT ... HDG		H40				
CODE	Width of Tray	Height H mm	Length L mm	Kg 1 pc	pcs	
YDT 410 HDG	100	40	100	0.113	50	
YDT 415 HDG	150	40	150	0.137	50	
YDT 420 HDG	200	40	200	0.160	50	
YDT 425 HDG	250	40	250	0.276	50	
YDT 430 HDG	300	40	300	0.311	50	
YDT 440 HDG	400	40	400	0.382	50	
YDT 445 HDG	450	40	450	0.417	25	
YDT 450 HDG	500	40	500	0.452	25	
YDT 460 HDG	600	40	600	0.523	25	

Brackets for Wall & Floor Mounting

Yere ve duvara Tespit Elemanı - Настенно-напольная консоль

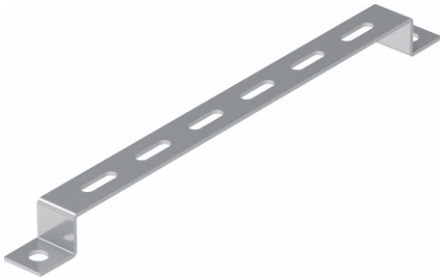

Pre-Galvanised

YDT ... PG		H50				
CODE	Width of Tray	Height H mm	Length L mm	Kg 1 pc	pcs	
YDT 510 PG	100	50	100	0.122	50	
YDT 515 PG	150	50	150	0.146	50	
YDT 520 PG	200	50	200	0.160	50	
YDT 525 PG	250	50	250	0.170	50	
YDT 530 PG	300	50	300	0.290	50	
YDT 540 PG	400	50	400	0.325	50	
YDT 545 PG	450	50	450	0.431	25	
YDT 550 PG	500	50	500	0.466	25	
YDT 560 PG	600	50	600	0.537	25	

Hot Dip Galvanised

YDT ... HDG		H50				
CODE	Width of Tray	Height H mm	Length L mm	Kg 1 pc	pcs	
YDT 510 HDG	100	50	100	0.122	50	
YDT 515 HDG	150	50	150	0.146	50	
YDT 520 HDG	200	50	200	0.160	50	
YDT 525 HDG	250	50	250	0.170	50	
YDT 530 HDG	300	50	300	0.290	50	
YDT 540 HDG	400	50	400	0.325	50	
YDT 545 HDG	450	50	450	0.431	25	
YDT 550 HDG	500	50	500	0.466	25	
YDT 560 HDG	600	50	600	0.537	25	

Brackets for Wall & Floor Mounting

Yere ve duvara Tespit Elemanı - Настенно-напольная консоль

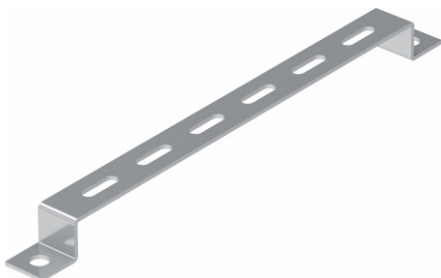

Pre-Galvanised

YDT ... PG		H60				
CODE	Width of Tray	Height H mm	Length L mm	Kg 1 pc	pcs	
YDT 610 PG	100	60	100	0.132	50	
YDT 615 PG	150	60	150	0.155	50	
YDT 620 PG	200	60	200	0.179	50	
YDT 625 PG	250	60	250	0.304	50	
YDT 630 PG	300	60	300	0.339	50	
YDT 640 PG	400	60	400	0.410	50	
YDT 645 PG	450	60	450	0.445	25	
YDT 650 PG	500	60	500	0.480	25	
YDT 660 PG	600	60	600	0.551	25	

Hot Dip Galvanised

YDT ... HDG		H60				
CODE	Width of Tray	Height H mm	Length L mm	Kg 1 pc	pcs	
YDT 610 HDG	100	60	100	0.132	50	
YDT 615 HDG	150	60	150	0.155	50	
YDT 620 HDG	200	60	200	0.179	50	
YDT 625 HDG	250	60	250	0.304	50	
YDT 630 HDG	300	60	300	0.339	50	
YDT 640 HDG	400	60	400	0.410	50	
YDT 645 HDG	450	60	450	0.445	25	
YDT 650 HDG	500	60	500	0.480	25	
YDT 660 HDG	600	60	600	0.551	25	

YDT H40

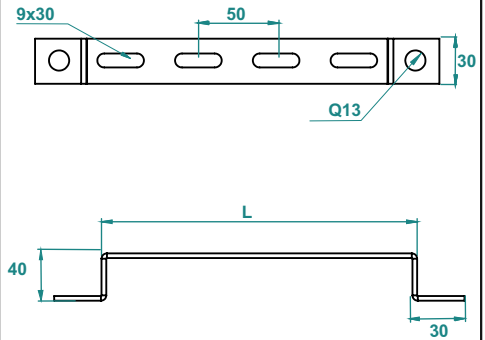

YDT H50

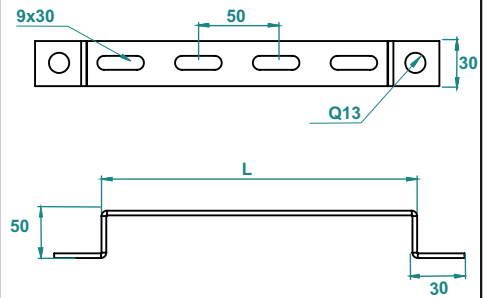

YDT H60

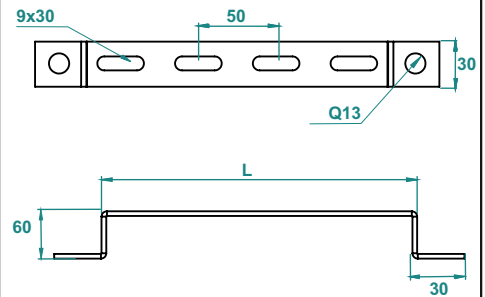

MATERIAL & FINISH

PG: Sendzimir method to TS - EN 10346:2011
 HDG-steel, hot-dip galv. to TS-EN ISO 1461:2011 (HDG)

Available Finishes:
 SS-Stainless steel AISI 304L and AISI 316L (SS)
 EP-Powder coating in a full range of colours (RAL)

1,5 kN Light Duty Wall Bracket (welded)

1,5 kN Hafif Seri Duvar Konsolu (Diştan Kaynaklı - Настенная консоль тяжёлая, сварная)

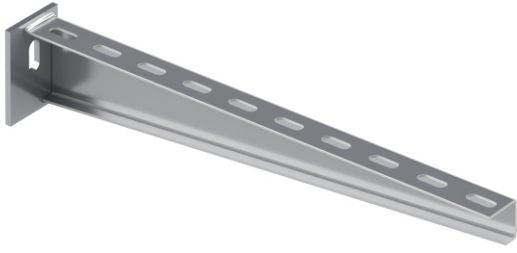

Welded part

Pre-Galvanised

DKH ... EG					
CODE	Length L mm	Base mm	Width of Tray	kg 1 pc	pcs
DKH 10 EG	110	40x4x60	100	0.170	50
DKH 15 EG	160	40x4x60	150	0.210	50
DKH 20 EG	210	40x4x60	200	0.250	50
DKH 25 EG	260	40x4x70	250	0.340	50
DKH 30 EG	310	40x4x70	300	0.390	25
DKH 40 EG	410	40x4x70	400	0.610	25
DKH 50 EG	510	40x4x80	500	0.820	20
DKH 60 EG	610	40x4x80	600	0.960	20

Hot Dip Galvanised

DKH ... HDG					
CODE	Length L mm	Base mm	Width of Tray	kg 1 pc	pcs
DKH 10 HDG	110	40x4x60	100	0.170	50
DKH 15 HDG	160	40x4x60	150	0.210	50
DKH 20 HDG	210	40x4x60	200	0.250	50
DKH 25 HDG	260	40x4x70	250	0.340	50
DKH 30 HDG	310	40x4x70	300	0.390	25
DKH 40 HDG	410	40x4x70	400	0.610	25
DKH 50 HDG	510	40x4x80	500	0.820	20
DKH 60 HDG	610	40x4x80	600	0.960	20

DKH ...

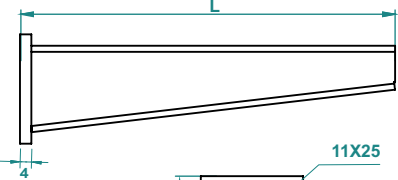
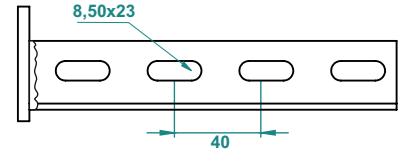

3,0 kN Medium Duty Wall Bracket (welded)

3,0kN Orta Seri Duvar Konsolu (diştan kaynaklı) - Настенная консоль средняя, сварная

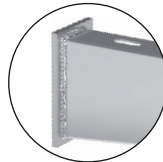
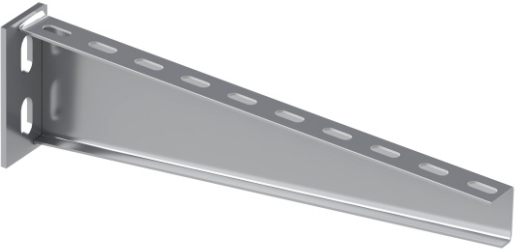

Welded part

Pre-Galvanised

DKO ... EG					
CODE	Length L mm	Base mm	Width of Tray	kg 1 pc	pcs
DKO 10 EG	110	50x5x70	100	0.240	50
DKO 15 EG	160	50x5x70	150	0.290	50
DKO 20 EG	210	50x5x70	200	0.340	50
DKO 25 EG	260	50x5x90	250	0.450	25
DKO 30 EG	310	50x5x90	300	0.510	25
DKO 40 EG	410	50x5x90	400	0.760	20
DKO 50 EG	510	50x5x90	500	0.900	20
DKO 55 EG	560	50x5x100	550	1.080	10
DKO 60 EG	610	50x5x100	600	1.150	10
DKO 70 EG	710	50x5x100	700	1.310	10

Hot Dip Galvanised

DKO ... HDG					
CODE	Length L mm	Base mm	Width of Tray	kg 1 pc	pcs
DKO 10 HDG	110	50x5x70	100	0.240	50
DKO 15 HDG	160	50x5x70	150	0.290	50
DKO 20 HDG	210	50x5x70	200	0.340	50
DKO 25 HDG	260	50x5x90	250	0.450	25
DKO 30 HDG	310	50x5x90	300	0.510	25
DKO 40 HDG	410	50x5x90	400	0.760	20
DKO 50 HDG	510	50x5x90	500	0.900	20
DKO 55 HDG	560	50x5x100	550	1.080	10
DKO 60 HDG	610	50x5x100	600	1.150	10
DKO 70 HDG	710	50x5x100	700	1.310	10

DKO ...

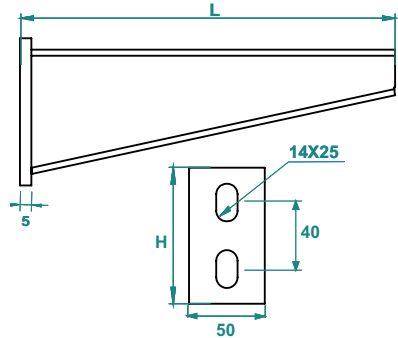
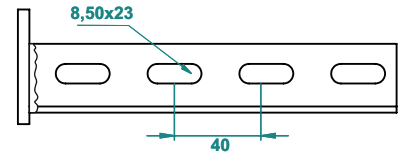

5,5kN Heavy Duty Wall Bracket (welded)

5,5kN Ağır Seri Duvar Konsolu (diştan kaynaklı) - Настенная консоль тяжёлая, сварная

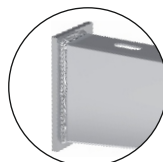

Welded part

Pre-Galvanised

DKA ... EG					
CODE	Length L mm	Base mm	Width of Tray	kg 1 pc	pcs
DKA 20 EG	210	50x5x120	200	0.650	20
DKA 30 EG	310	50x5x120	300	0.840	20
DKA 40 EG	410	50x5x140	400	1.180	10
DKA 50 EG	510	60x6x140	500	1.520	10
DKA 55 EG	560	60x6x160	550	1.770	10
DKA 60 EG	610	60x6x160	600	1.890	10
DKA 70 EG	710	60x6x190	700	2.430	5
DKA 80 EG	810	60x6x190	800	3.240	5
DKA 90 EG	910	60x6x230	900	4.220	4
DKA 100 EG	1010	60x6x100	1000	5.210	4

Hot Dip Galvanised

DKA ... HDG					
CODE	Length L mm	Base mm	Width of Tray	kg 1 pc	pcs
DKA 20 HDG	210	50x5x120	200	0.650	20
DKA 30 HDG	310	50x5x120	300	0.840	20
DKA 40 HDG	410	50x5x140	400	1.180	10
DKA 50 HDG	510	60x6x140	500	1.520	10
DKA 55 HDG	560	60x6x160	550	1.770	10
DKA 60 HDG	610	60x6x160	600	1.890	10
DKA 70 HDG	710	60x6x190	700	2.430	5
DKA 80 HDG	810	60x6x190	800	3.240	5
DKA 90 HDG	910	60x6x230	900	4.220	4
DKA 100 HDG	1010	60x6x100	1000	5.210	4

DKA ...

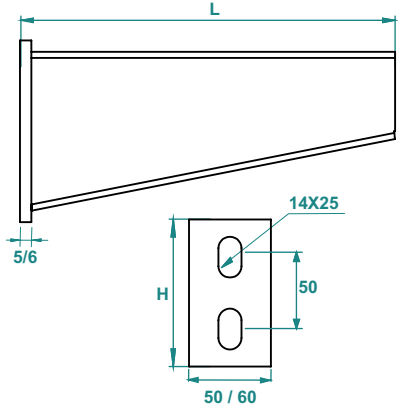
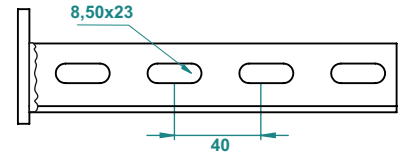

MATERIAL & FINISH

EG: Electro-galvanized (8-12 micron) EN ISO 2081
HDG: steel, hot-dip galv. to TS-EN ISO 1461:2011 (HDG)

Available Finishes:

SS-Stainless steel AISI 304L and AISI 316L (SS)
EP-Powder coating in a full range of colours (RAL)